

Power Supplies for IEEE802.3af Compliant Power Devices

Three practical transformer-coupled circuits are detailed for providing isolated load power from power-over-LAN or power-via-MDI systems. All circuits employ a hot-swap switch to allow hot plug-in operation and a current-mode-switching controller to provide three possible load requirements.

The first is a 6W flyback supply offering 4.25W output. The second is a forward converter with synchronous rectification to provide 3.3V or 5V at 2.5A. The third is a forward converter with synchronous rectification to provide a triple output at 14.2W. All are transformer coupled to provide and 1500Vrms isolation. Complete design information is given including circuits, component values, important waveforms, and efficiency data.

Additional Information: [Quick View Data Sheet for the MAX5003](#)
[Quick View Data Sheet for the MAX5014](#)
[Quick View Data Sheet for the MAX5910/MAX5917](#)

Power-Over-LAN or Power-Via-MDI (Media Dependent Interface) is a network infrastructure to deliver 48V power over the existing network Category 5 (CAT-5) data cable. Power-Over-LAN provides signals as well as power to the connected power devices (PDs) such as IP Phones and Wireless Access Nodes, eliminating the need for local power sources.

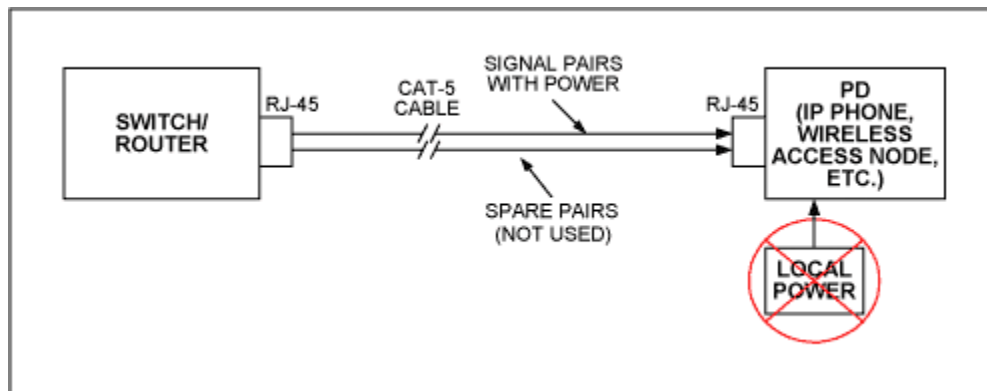

Figure 1. Power over signal pairs.

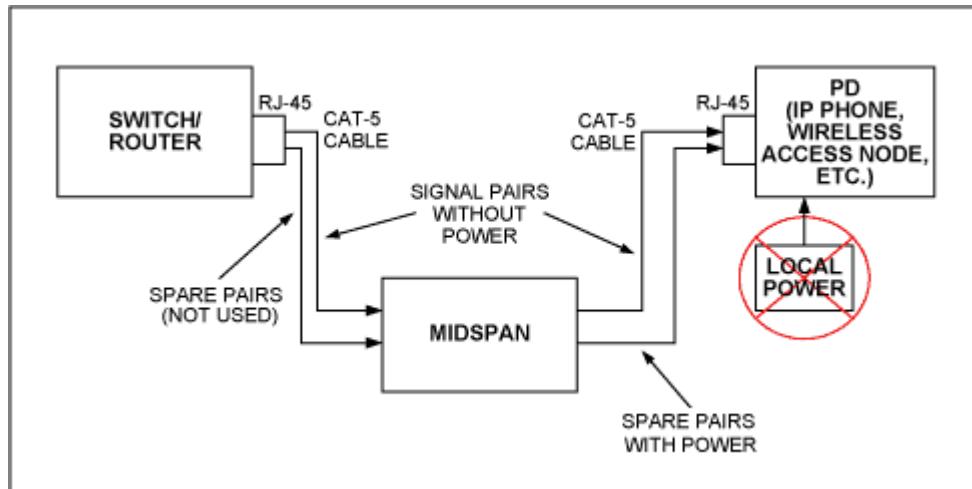

Figure 2. Power over spare pairs (Mid Span Power Insertion).

To accept power from a Power-Over-LAN system, a PD must meet the IEEE802.3af standard specification. A MAX5910 or a MAX5917 hot swap switch and a MAX5014 or MAX5003 PWM controller PWM controller chip set provides an 802.3af compliant power solution for PD designs to suit various power levels. The devices offer the following key features:

- Discovery signature
- Low leakage
- +65V operating voltage
- Current limit
- Programmable under voltage lock out
- Isolated DC/DC converter
- 1500Vrms isolation

Table 1. Input Leakage Current (measured without the 25K signature resistor)

Leakage Current						
Input Voltage	T _A = 150°C	T _A = 125°C	T _A = 100°C	T _A = 75°C	T _A = 50°C	T _A = 25°C
12V	1.60µA	0.27µA	0.043µA	7.75nA	1.25nA	0.37nA
20V	2.13µA	0.28µA	0.043µA	8nA	1.7nA	0.7nA

Channel 1: Input Voltage 42V, CAT-5 cable resistance: 20 Ohm

Channel 2: GND (with respect to point B)

Channel 3: Output Voltage, Load = 330µF and 191 Ohm

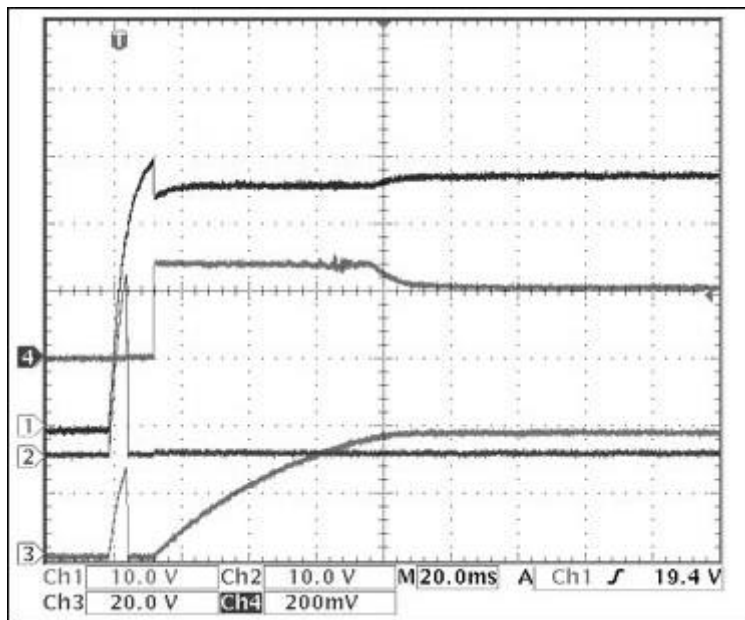

Figure 4. Power-up wave form.

I. Single Output Isolated 6W Power Supply

Figure 5 shows a schematic for a 6W single output power supply using the MAX5910 hot-swap IC along with the MAX5014 PWM IC.

V_{in} = 36-56VDC

V_{out} = 4.25V

I_{out} = 1.4A Isolated power supply (1500VDC isolation)

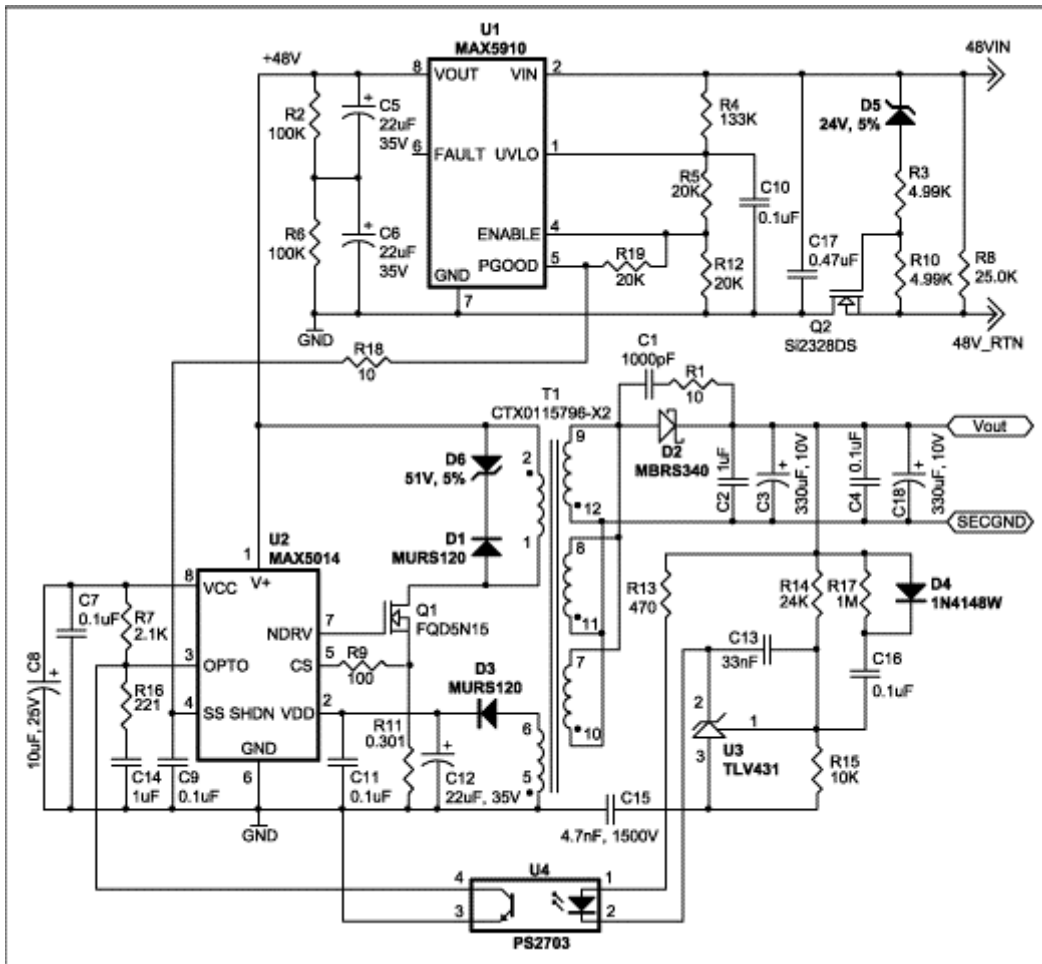

Figure 5. Six watt single-output power supply.

Table 2. Component List for 6W Power Supply Circuit of Figure 5

Designation	Qty	Description
C1	1	Ceramic capacitor 1000pf, 10%,50V, X7R (0805)
C2, C14	2	Ceramic capacitor 1 μ F, 10%, 50V, X7R (1206)
C3, C18	2	Tantalum capacitor 330 μ F,10V, 10%
		Kemet T494X337K010AS
C8	1	Tantalum capacitor 10 μ F, 25V, 10%
		Vishay 293D106X9025C2
C13	1	Ceramic capacitor 0.033 μ f, 10%, 50V, X7R (0805)
C15	1	4.7nF, 250VAC, X&R ceramic capacitor (3045)
		Murata GHM3045-X7R472K-GC
C17	1	Ceramic capacitor 0.47 μ f, 10%, 100V
		Panasonic ECW1474KCV
D1, D3	1	Diode 1A, 200V Onsemi MURS120
D2	1	Diode Schottky 3A, 40V Onsemi MBRS340
D4	1	Diode 75V, 100ma Diodes Inc 1N4148W
D5	1	Zener diode 24V, 5%, 150mw
D6	1	Zener diode 51V, 5%, 3W Vishay BZG05C51
Q1	1	150V, 5A N-channel MOSFET Fairchild FQD5N15
Q2	1	100V, 1.5A N-channel MOSFET SOT23
		Si2328DS
R1	1	Resistor 10 ohms, 5% (0805)
R2, R6	2	Resistor 100K, 5% (0805)
R3, R10	2	Resistor 4.99K, 1% (0805)
R4	1	Resistor 133K, 1% (0805)
R5, R12	2	Resistor 20K, 1% (0805)
R7	1	Resistor 2.1K, 1% (0805)

R8	1	Resistor 25K, 5%, (1206)
R9	1	Resistor 100, 5% (0805)
R11	1	Resistor 0.301 ohm, 1% (0805)
R13	1	Resistor 470, 5% (0805)
R14	1	Resistor 24K, 1% (0805)
R15	1	Resistor 10K, 1% (0805)
R16	1	Resistor 221, 1% (0805)
R17	1	Resistor 1M, 5% (080)
R18	1	Resistor 10, 5% (0805)
T1	1	Transformer Coiltronics CTX0115796-X2
		200 μ H, 1:0.1666:0.5
U1	1	+65V Simple Swapper Hot Swap Switch MAX5910ESA
U2	1	Current mode PWM controller MAX5014CSA
U3	1	1.24V precision shunt regulator (SOT23)
		Texas Instruments TLV431AIDBV
U4	1	Opto-coupler 4pin SOP
		California Eastern labs PS2703-1

Performance data for circuit in Figure 5.

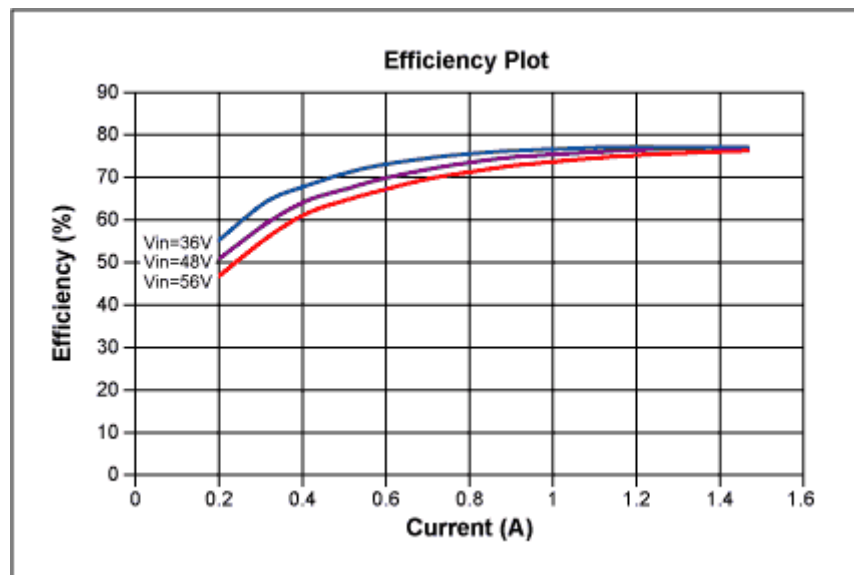

Figure 6. Efficiency plots for circuit in Figure 5: (DC-DC converter + hot-swap section).

Power up Waveforms (0-Ohm line impedance)

Ch1-Input voltage (10V per division)

Ch2-Input current (0.1A per division)

Ch3-Output voltage (1V per division)

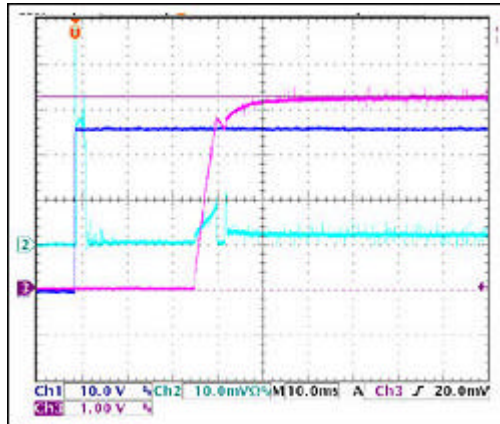

Figure 7. Power up waveform at $V_{in} = 36V$ and no load.

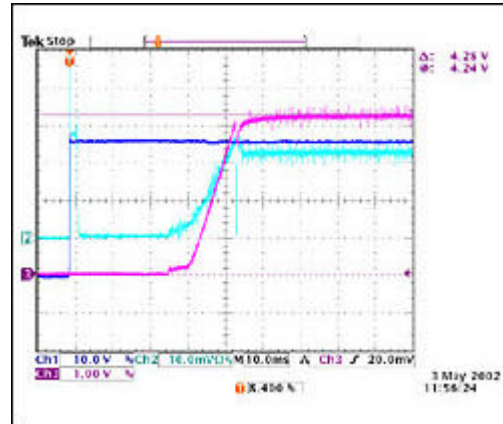

Figure 8. Power up waveform at $V_{in} = 36V$ and full load.

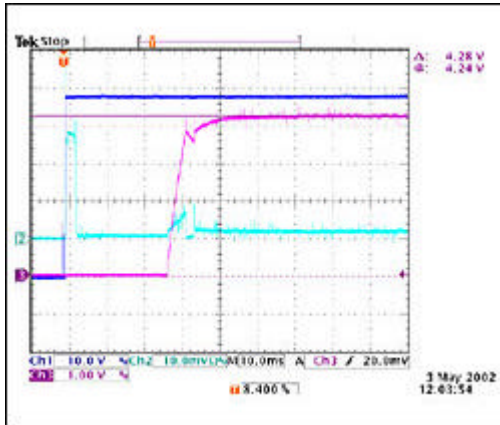

Figure 9. Power up waveform at $V_{in} = 48V$ and no load.

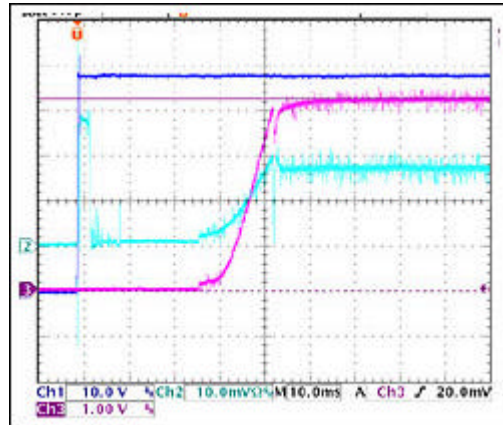

Figure 10. Power up waveform at $V_{in} = 48V$ and full load.

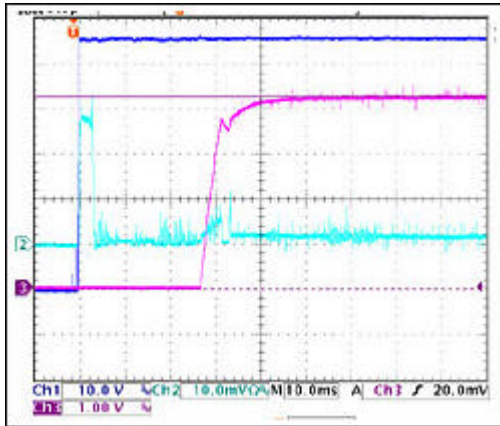

Figure 11. Power up waveform at $V_{in} = 56V$ and no load.

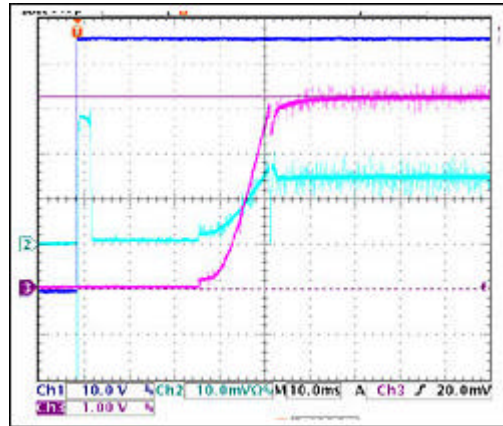

Figure 12. Power up waveform at $V_{in} = 56V$ and full load.

Power up Waveforms (20 ohm line impedance)

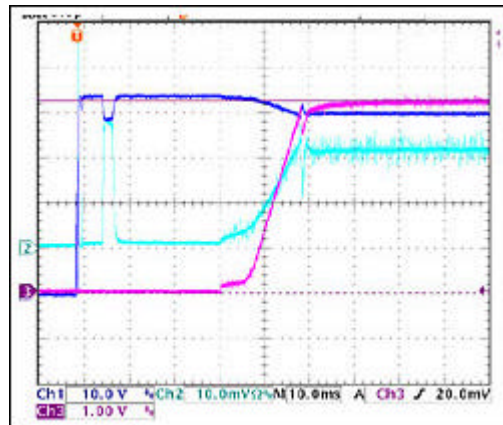
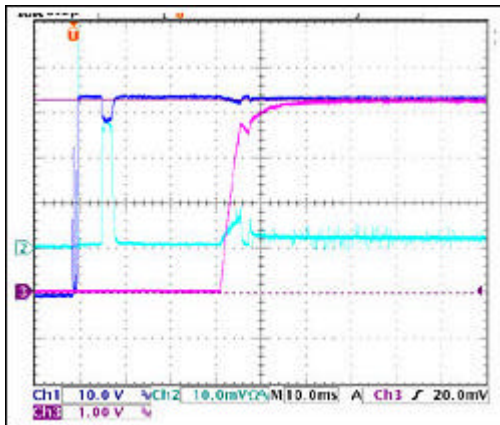

Figure 13. Power up waveform at $V_{in} = 44V$ and no load.

Figure 14. Power up waveform at $V_{in} = 44V$ and full load.

II. Single Output 8.25W or 12.5W Power Supply with High-Efficiency Using Synchronous Rectification

Figure 15 shows the schematic of a single output 8.25/12.5 watts power supply.

Input voltage 30-60V DC
Output voltage 3.3V or 5V DC
Output current 2.5A
Isolation 1500VDC

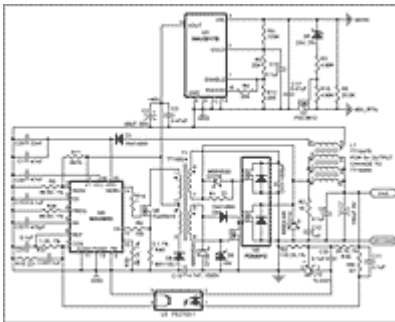

Figure 15. Single-output 3.3V or 5V 2.5A 8.25/125 W power supply.

Table 3. Component List for the Power Supply Circuit in Figure 15

Reference Designator	Qty	Description
C1, C29	2	47nF ceramic capacitor (0805)
C2	1	Electrolytic capacitor 68 μ F; 80V Panasonic EEVFK1K680Q
C3, C17	3	Film capacitor 0.47 μ F, 100V Panasonic ECWU1474KCV
C5	1	Ceramic capacitor 1000pF (0805)
C7	1	Capacitor AO 150 μ F, 6V Kemet A 700X157M006A T
C8, C10, C11, C15, C31, C30	6	Ceramic capacitor .1 μ F (0805)
C33	1	Ceramic capacitor 1 μ F, 16V (0805)
C12	1	Ceramic capacitor 1nF, 100V (0805)
C13	1	Ceramic capacitor 4.7nF 1500V
C28	1	Ceramic capacitor 22nF (0805)
C32	1	Ceramic capacitor 470pF (0805)
D1, D9	1	Diode 100ma, 75V 1N4148W
D3, D13	2	Diode Schottky 0.5A, 30V MBRS0530
D5	1	Zener diode 24V, 5% SOD-123
D6	1	Diode 200ma. 200V Panasonic MA115CT
D8	1	Zener diode 18V, 5%
D14	1	Diode Schottky 3A, 40V MBRS340
L1	1	Output choke 6.8 μ H Transpower (TTI8470)/ change to TTI8454 for 5V
T1A	1	Transformer Transpower (TTI8524)
Q1	1	30V N-Channel MOSFET Fairchild FDN361AN (SOT23)
Q2	1	100V 1.5A N-Channel MOSFET SOT23
Q6	1	150V, 5A N-Channel MOSFET (DPAK)

		Fairchild FQD5N15
R1	1	Resistor 22 ohms (0805)
R2	1	Resistor 10 ohms (1206)
R3, R10	2	Resistor 4.99K, 1% (0805)
R4	1	Resistor 133K, 1% (0805)
R5, R16, R12	2	Resistor 20K 1% (0805)
R11	1	Resistor 887K, 1% (0805)
R7	1	Resistor 330 ohms 5% (0805)
R8	1	Resistor 25K 1% (1206)
R9		Resistor 36.5K 1% (0805)
R14	1	Resistor 1 ohm 5% (0805)
R15	1	Resistor 221, 1% (0805)
R35	1	Resistor 26.7K, 1% (0805)
R36	1	Resistor 66.5K, 1% (0805)
R37	1	Resistor 1.24K, 1% (0805)
R38	1	Resistor 100 ohms, 5% (0805)
R39	1	Resistor 68.1K, 1% (0805)
R40	1	Resistor 0.1 ohm 1% (1206)
R41	1	Resistor 16.2K, 1% (0805)/ change to 8.87K, 1% (0805) f or 5V
U1	1	Dual 30V MOSFETS FDS6912 (SO8)
U2	1	+65V Simple Swapper Hot Swap Switch
		MAX5917B
U3	1	Optocoupler California Eastern Labs PS2703-1
U4	1	Voltage mode PWM controller
		MAX5003
U10	1	Precision 1.25V reference TLV431

Performance Data for the Circuit in Figure 15

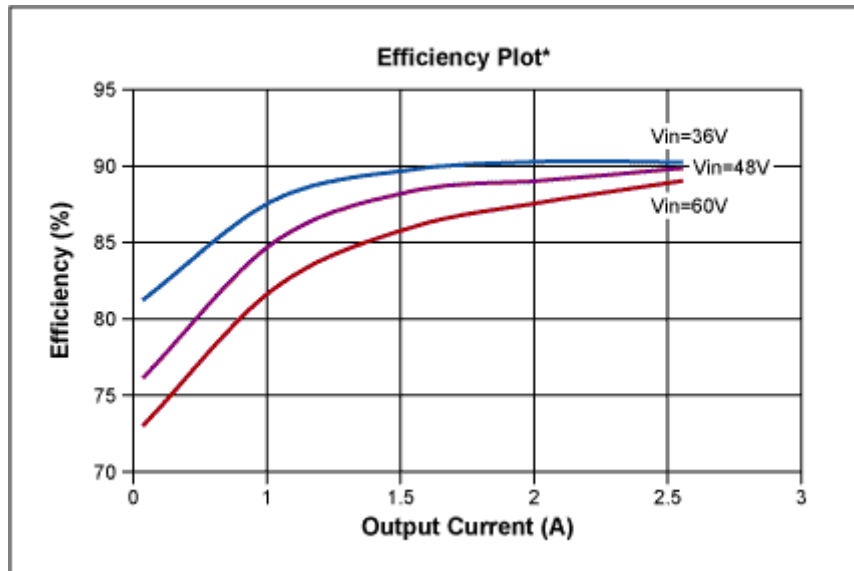

Figure 16. Efficiency plot for 3.3V output.

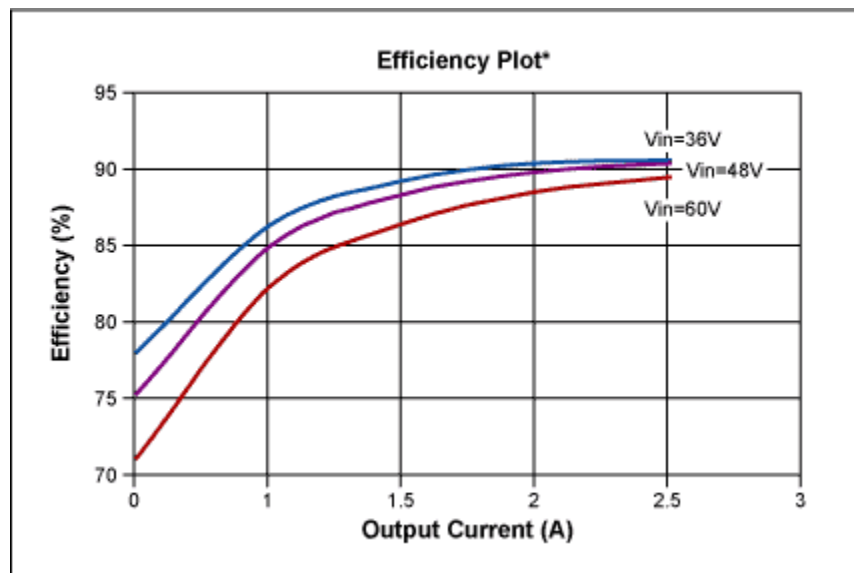

Figure 17. Efficiency plot for 5V output.

*Note: The efficiency data taken did not include the hot swap section.

Voltage Waveforms

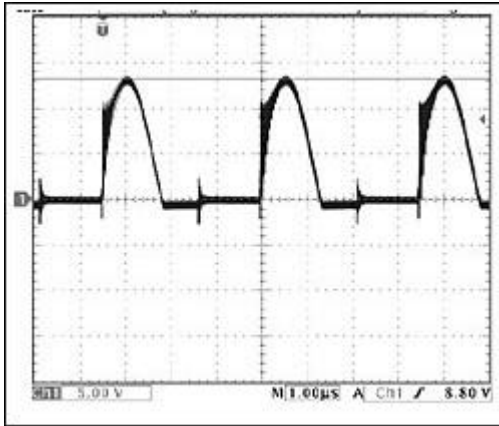

Figure 18. Voltage across capacitor C5 at an input voltage of 36V and load of 2.5A.

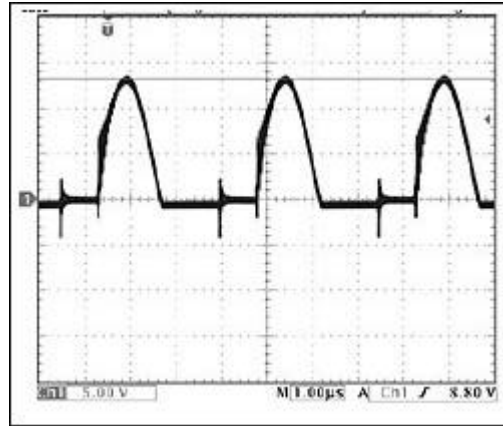

Figure 19. Voltage across capacitor C5 at an input voltage of 60V and load of 2.5A.

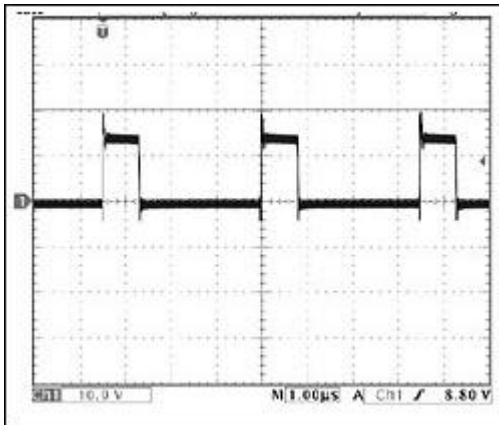

Figure 20. Voltage across D14 at an input voltage of 60V and a load of 2.5A.

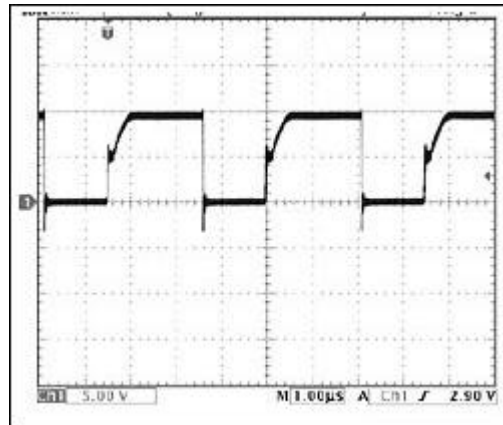

Figure 21. Voltage across the drain to source of Q1 at an input voltage of 36V and a load of 2.5A.

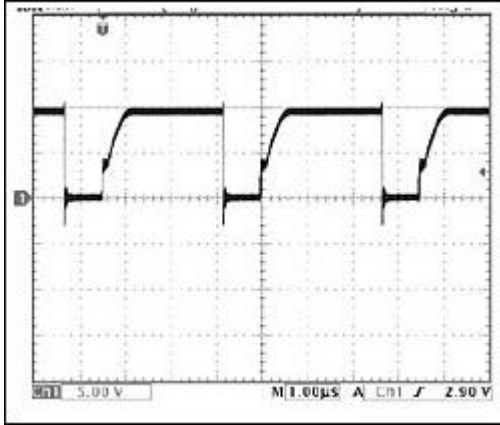

Figure 22. Voltage across Drain to Source of Q1 at an input voltage of 36V and a load of 2.5A.

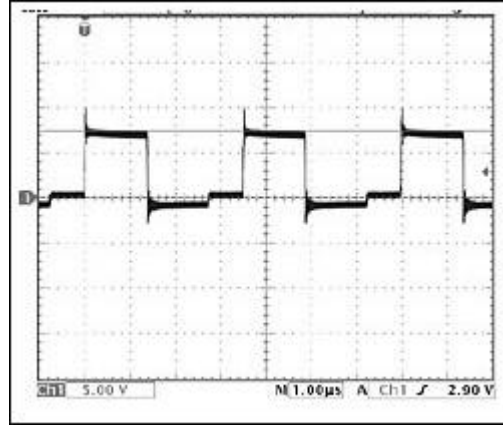

Figure 23. Voltage across Gate to Source of Q1 at an input voltage of 36V and a load of 2.5A.

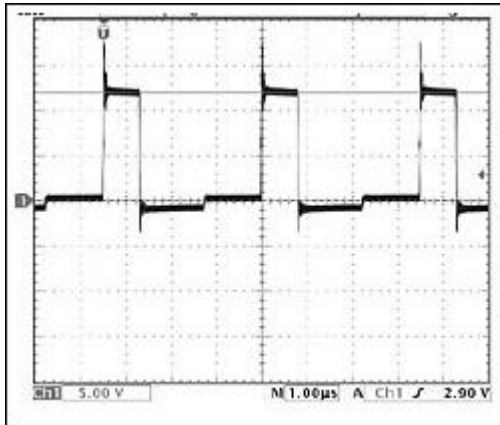

Figure 24. Voltage across Gate to Source of Q1 at an input voltage of 60V and a load of 2.5A.

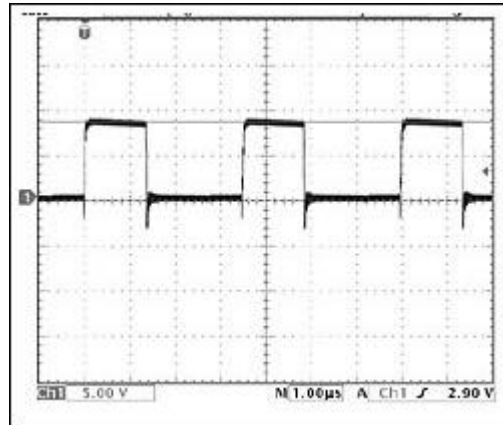

Figure 25. Voltage across Gate to Source of the top FET in U1 at an input voltage of 36V.

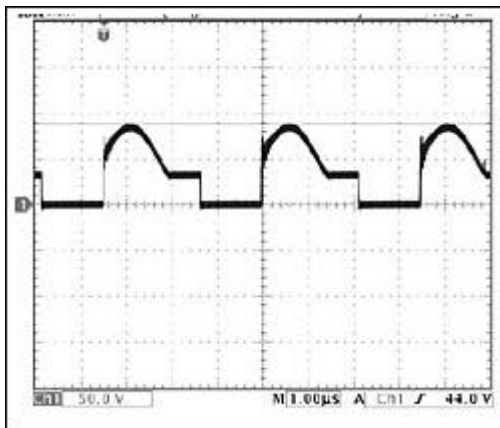

Figure 26. Voltage across Drain to Source of Q6 at an input voltage of 36V and a load of 2.5A.

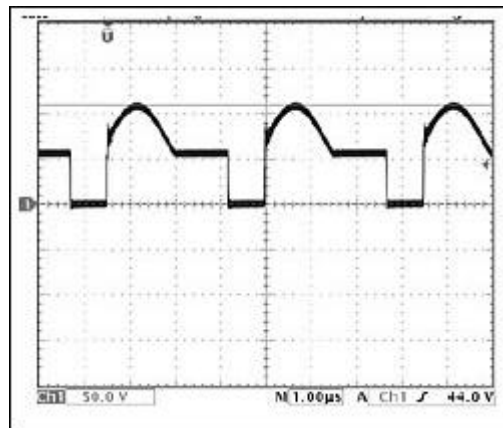

Figure 27. Voltage across Drain to Source of Q6 at an input voltage of 60V and a load of 2.5A.

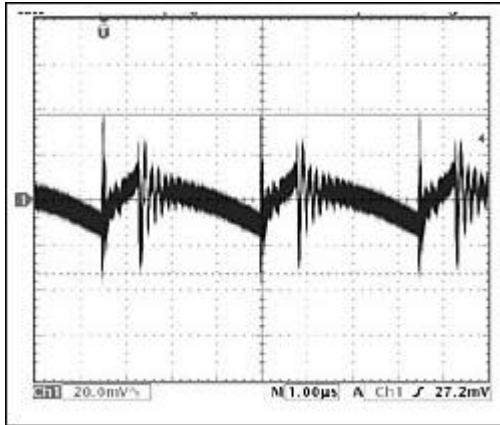

Figure 28. Output ripple and noise at an input of 60V and a load of 2.5A (BW = 150Mhz).

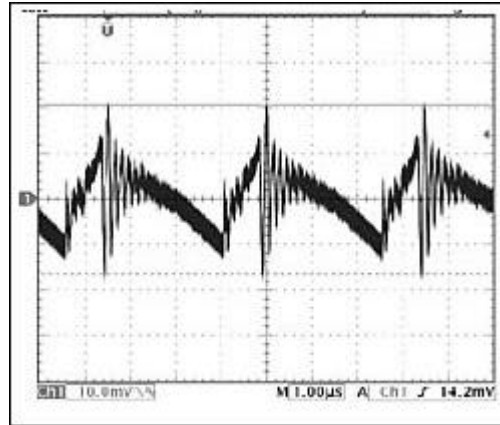

Figure 29. Output ripple and noise at an input of 36V and a load of 2.5A (BW = 20Mhz).

III. Triple output 14.2W High-Efficiency Isolated Power Supply Using Synchronous Rectification

Figure 30 is a schematic for a triple output isolated power supply with the hot-swap feature.

Input voltage: 36-60V DC

Outputs: 5V@2A $\pm 2\%$ regulation, 7.5V@0.5A $\pm 5\%$ regulation from 10% load to full load, 22V@20ma $\pm 5\%$ regulation from 10% load to full load.

Isolation: 1500VDC

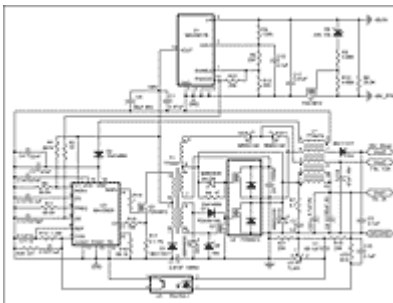

[For larger image](#)

Figure 30. Triple-output isolated supply with hot-swap feature.

Table 4. Component List for the Power-Supply Circuit in Figure 30

Designator	Qty	Description
C1, C17	2	47 μ F, 100V ceramic capacitor (2220)
C3, C10, C11, C13, C15, C16	6	.1 μ F, 50V ceramic capacitor (0805)
C4	1	22nF, 50V ceramic capacitor (0805)
C2, C14	2	47nF, 50V ceramic capacitor (0805)
C5	1	68 μ F, 80V Electrolytic capacitor
		Panasonic EEVFK1680Q
C6	1	1000pF, 50V ceramic capacitor(0805)
C9	1	47 μ F, 10V tantalum capacitor
C7	1	1nF, 100V ceramic capacitor (0805)
C8	1	150 μ F AO capacitor/120 μ F SP capacitor
		A700X157M006AT (Kemet)
		EEFUD0J121XR (Panasonic)
C12	1	470pF, 50V ceramic capacitor (0805)
C18	1	4.7nF, 1500V ceramic capacitor
C19	1	1 μ F, 10V ceramic capacitor (0805)
C20	1	4.7 μ F, 6.3V ceramic capacitor
D7, D2	2	100ma. 75V signal

		diode (SOT23) 1N4148W
D3, D11	2	1A, 40V Schottky Onsemi MBR5140
D4	1	200ma, 100V diode Panasonic MA111CT
D1	1	200ma, 200V diode Panasonic MA115CT
D5	1	24V, 5% Zener diode(SOD-123)
D6	1	18V, 5% Zener diode(SOD-123)
D8, D9	2	500ma, 30V Schottky Onsemi MBR0530
D10	1	3A, 30V Schottky Onsemi MBR5330
L1	1	Coupled choke, Transpower TTI8474
T1	1	Transformer, Transpower TTI8431
Q1	1	N-Channel MOSFET, 100V, 1.5A, Si2328DS
Q2	1	N-Channel MOSFET, 30V, 1.8A Fairchild FDN361AN
Q3	1	200V, 5A MOSFET Fairchild FDD2612 (DPAK)
R6	1	47 ohms 5% (0805)
R7	1	4.7 ohms 5% (1206)
R1	1	887K 1% (0805)
R18	1	470 ohms, 5% (0805)

R9	1	36.5K, 1% (0805)
R2	1	10 ohms, 5% (0805)
R13	1	1.24K, 1% (0805)
R4	1	133K, 1% (0805)
R14	1	1 ohm 5% (0805)
R15	1	100 ohms, 5% (0805)
R11	1	66.5K, 1% (0805)
R17	1	.1 ohm, 1% (1206)
R19, R21, R5, R12, R22	5	20K, 1% (0805)
R16	1	68.1K, 1% (0805)
R20	1	221 ohms, 1% (0805)
U1	1	+65V Simple Swapper Hot Swap Switch MAX5917B
U2	1	Dual MOSFET 30V Fairchild FDS6912 (SO8)
U3	1	High voltage power supply controller
		MAX5003CSE
U4	1	Optocoupler California Eastern Labs PS2703M-1
U5	1	Reference 2.5V (SOT23) Texas Instruments TL431

Table 5. Performance Data of the Circuit in Figure 30

Vin (V)	Iin (A)	Vo1 (V)	Io1(A)	Vo2(V)	Io2(A)	Vo3(v)	Io3(ma)	Eff(%)*
36	0.437	5.014	2.02	7.278	0.49	22.487	19.68	89.86171
48	0.33	5.014	2.02	7.297	0.49	22.691	19.85	89.35749
60	0.267	5.014	2.02	7.31	0.49	22.805	19.95	88.4216
72	0.226	5.014	2.02	7.32	0.49	22.91	20.04	87.10789
30	0.534	5.014	2.02	7.275	0.49	22.236	19.4	88.16734
30	0.1816	5.02	0.13	7.142	0.485	21.168	19.95	83.31079
36	0.149	5.021	0.13	7.141	0.485	21.415	20.2	84.80048
48	0.115	5.02	0.13	7.145	0.485	21.527	20.31	82.52062
60	0.0988	5.02	0.13	7.136	0.5	21.561	20.34	78.59566
72	0.086	5.02	0.13	7.139	0.495	21.623	20.39	74.73026
72	0.1718	5.014	2.02	7.821	0.05	24.74	2.04	85.44981
60	0.1996	5.014	2.02	7.871	0.05	24.79	2.05	88.28198
48	0.2459	5.014	2.02	7.724	0.05	24.06	1.99	89.48725
36	0.3237	5.014	2.02	7.588	0.05	23.341	1.93	90.55648
30	0.394	5.014	2.02	7.527	0.05	23	1.9	89.24137

*Note: The efficiency data did not include the hot-swap section drops.

MORE INFORMATION

MAX5003: [QuickView](#) -- [Full \(PDF\) Data Sheet \(232k\)](#) -- [Free Samples](#)

MAX5014: [QuickView](#) -- [Full \(PDF\) Data Sheet \(328k\)](#) -- [Free Samples](#)

MAX5910: [QuickView](#) -- [Full \(PDF\) Data Sheet \(288k\)](#) -- [Free Samples](#)

MAX5917: [QuickView](#) -- [Full \(PDF\) Data Sheet \(288k\)](#) -- [Free Samples](#)